

“twister”™ 2111

10Mbps Media Converter

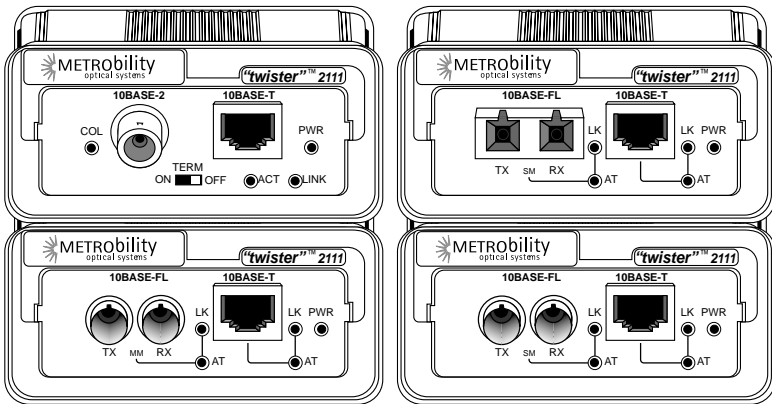

Installation & User Guide

Models: 2111-12-01 / 2111-13-01 / 2111-15-01 /
2111-16-01 / 2111-18-01 / 2111-1T-01

Metrobility 10Mbps “twister”™ Standalone Media Converters

2111-12-01 _____ RJ-45 to BNC
2111-13-01 _____ RJ-45 to FL multimode SC
2111-15-01 _____ RJ-45 to FL multimode ST
2111-16-01 _____ RJ-45 to FL singlemode ST
2111-18-01 _____ RJ-45 to FL multimode SMA
2111-1T-01 _____ RJ-45 to FL multimode ST (LH)

This publication is protected by the copyright laws of the United States and other countries, with all rights reserved. No part of this publication may be reproduced, stored in a retrieval system, translated, transcribed, or transmitted, in any form, or by any means manual, electric, electronic, electromagnetic, mechanical, chemical, optical or otherwise, without prior explicit written permission of Metrobility Optical Systems, Inc.

Table of Contents

“twister” 2111 Media Converter Installation & User Guide

Introduction	4
Overview	5
Installation Guide	6
STEP 1: Unpack the “twister” and Accessories	6
STEP 2: Choose an Appropriate Location	6
STEP 3: Set the Switches	7
Link Loss Carry Forward (LLCF) Switch	7
Termination Switch	8
MDI-II to MDI-X Switch	9
STEP 4: Connect to the Network	10
Twisted-pair	10
Fiber Optic	11
BNC	12
STEP 5: Apply Power	14
User Guide	16
System LEDs	16
Link Loss Carry Forward (LLCF)	17
Topology Solutions	18
Technical Specifications	19
Product Safety, EMC and Compliance Statements	21
Warranty and Servicing	22

Lancast is a registered trademark; Metrobility Optical Systems, the Metrobility Optical Systems logo, and “twister” are trademarks of Metrobility Optical Systems, Inc. All others are trademarks of their respective owners.

The information contained in this document is assumed to be correct and current. The manufacturer is not responsible for errors or omissions and reserves the right to change specifications at any time without notice.

Introduction

Thank you for choosing Metrobility “twister” media converters.

Metrobility “twister” media converters represent the hottest technology available for extending Ethernet and Fast Ethernet networks. Since Metrobility first developed “twister” media conversion, it has become a standard for providing a cost-effective means of integrating a mixed media environment. As LANs grow and evolve, this technology provides an ideal solution for building effective migration strategies.

These IEEE 802.3 compliant media converters are compatible with Ethernet devices from other leading network technology providers. This increases the flexibility of your network configuration by ensuring reliable data transmission in multi-vendor as well as mixed media environments.

The information in this guide will help you to install and start using your “twister” 2111 media converter.

Overview

The Metrobility “twister” 2111 10Mbps media converter provides seamless integration of 10BASE-T Category 3, 4 and 5 twisted-pair segments with singlemode and multimode 10BASE-FL fiber optic segments as well as thinnet coax in Ethernet environments.

To optimize your Ethernet network, the media converter provides seamless operation in half-duplex or full-duplex environments. Full signal restoration—with a low bit delay — ensures accurate data transmission to and from LANs within an organization. All signal activity is completely converted ensuring accurate communication and collision detection in connected segments and allowing maximum media length to be achieved on either side of the device.

The “twister” 2111 provides the following key features:

- A Link Loss Carry Forward (LLCF) enable/disable switch* is included to provide an easy means for troubleshooting a remote network connection. Refer to the section of this guide titled [Link Loss Carry Forward](#) for more information.
- All twisted-pair ports are equipped with an MDI-II to MDI-X switch eliminating the need for crossover cables.
- Auto polarity support on all twisted-pair ports.

Whether you are updating or expanding your existing network, the Metrobility line of “twister” media converters supports a wide range of configuration needs. The “twister” 2111 includes the following media conversion combinations:

Universal Power Supply (90-250V)

2111-12-01	RJ-45 to BNC
2111-13-01	RJ-45 to FL multimode SC
2111-15-01	RJ-45 to FL multimode ST
2111-16-01	RJ-45 to FL singlemode ST
2111-18-01	RJ-45 to FL multimode SMA
2111-1T-01	RJ-45 to FL multimode ST (LH)

* Does not apply to the “twister” 2111-12 (BNC).

Installation Guide

Follow the simple steps outlined in this section of the guide to install and start using your Metrobility “twister” media converter.

1 **Unpack the “twister” and any accessories.**

Check that the following components have been included with your order:

- “twister” 2111 media converter
- Power supply
- Power cord
- Four (4) rubber feet

Your order has been provided with the safest possible packaging, but shipping damage does occasionally occur. Inspect your order carefully. If you discover any shipping damage, notify the carrier and follow their instructions for damage and claims. Save the original shipping carton if return or storage of the unit is necessary.

2 **Choose an appropriate location.**

The “twister” 2111 media converter is intended for use in either office or industrial environments. The unit must be located within six (6) feet of the AC power source being used and placed as far away as possible from electrical noise generating equipment such as copiers, electrostatic printers and other motorized equipment. If exposed twisted-pair wiring is used nearby, the wiring should be routed as far away as possible from power cords and data cables to minimize interference.

The units may be oriented in any manner that permits you to make physical connection to the power supply and leaves a minimum of six (6) inches of space for proper ventilation.

TUV Compliance Note: For pluggable equipment, the socket outlet must be installed near the equipment and be easily accessible.

Bei Geräten mit Steckanschluß muß die Steckdose nahe dem Gerät angebracht und leicht zugänglich sein.

3

Set the switches.

Link Loss Carry Forward (LLCF) Switch.*

The 2111 media converter incorporates Link Loss Carry Forward (LLCF) functionality as an aid in troubleshooting a remote connection.

A switch for enabling/disabling LLCF is located on the rear panel of the converter. When LLCF is enabled, the fiber optic ports as well as the twisted-pair ports on the “twister” media converter do not transmit a link signal until they receive a link signal from the opposite port. Refer to the page titled [Link Loss Carry Forward](#) in the User Guide section of this manual for more detailed information.

The unit is shipped with LLCF disabled (OFF). To enable LLCF, simply slide the switch to the ON position.

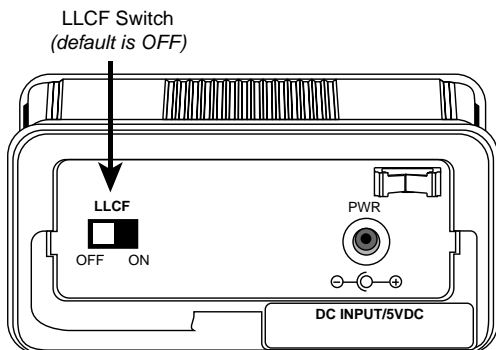

* Does not apply to the “twister” 2111-12 (BNC).

Termination Switch (2111-12-01 only)

The “twister” 2111-12-01 has a termination switch located on the front panel. This switch is used to set either internal or external termination of the BNC port.

External termination is enabled when the switch is in the OFF position (*default*). Use this setting if the “twister” will be used in a daisy-chain configuration or if you must use a BNC T-connector and terminator for proper external termination.

Internal 50Ω termination is enabled when the switch is in the ON position. To change the setting, use a pointed object to slide the switch. When internal termination is enabled, the unit’s BNC port can be connected directly to another device, without the use of an external BNC terminator.

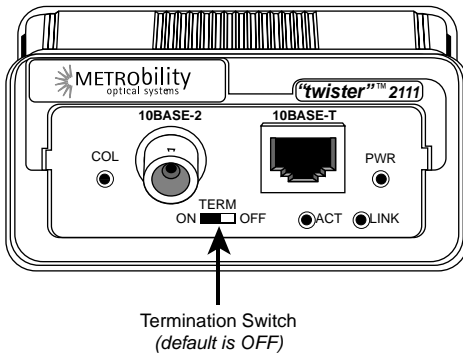

MDI-II to MDI-X Switch

All “twister” media converters with twisted-pair ports have an MDI-II to MDI-X switch that eliminates the need for crossover cables. This switch is located on the bottom of the unit directly below the RJ-45 connector and allows simple setup in either straight through or crossover configurations. Refer to the illustration below.

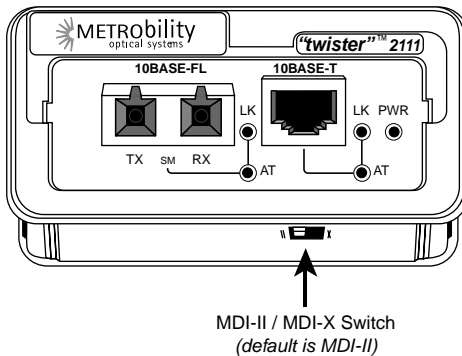

When setting the MDI-II to MDI-X switch, observe the positioning of the following symbols:

- The parallel symbol (||) indicates a straight through or parallel connection. (*default*)
- The cross symbol (X) indicates a crossover connection.

These symbols are clearly marked on the bottom of the unit. Using a pointed object, simply slide the switch in the direction of the appropriate symbol. Use the following table as a guide:

A device that is wired straight through, needs one crossover connection:	
If the cable is...	... the MDI-II to MDI-X Switch Setting should be
straight through	X
crossover	

A device that is wired crossover, needs a parallel connection:	
If the cable is...	... the MDI-II to MDI-X Switch Setting should be
straight through	
crossover	X

4

Connect to the network.

The Metrobility “twister” 2111 media converter offers the ease of plug-and-play installation. Refer to the appropriate section below for more information and guidelines regarding specific network connections.

Twisted-pair Connections *(all models)*

The “twister” 2111 provides one shielded RJ-45 connector for Category 3, 4 or 5 twisted-pair segments and supports a maximum link length of 100 meters.

NOTE: Be sure you have set the MDI-II to MDI-X switch located on the bottom of the unit to the proper configuration. Refer back to STEP 3 if necessary.

Once power is applied to the unit, correct connectivity can be verified via the link (LK) LED.

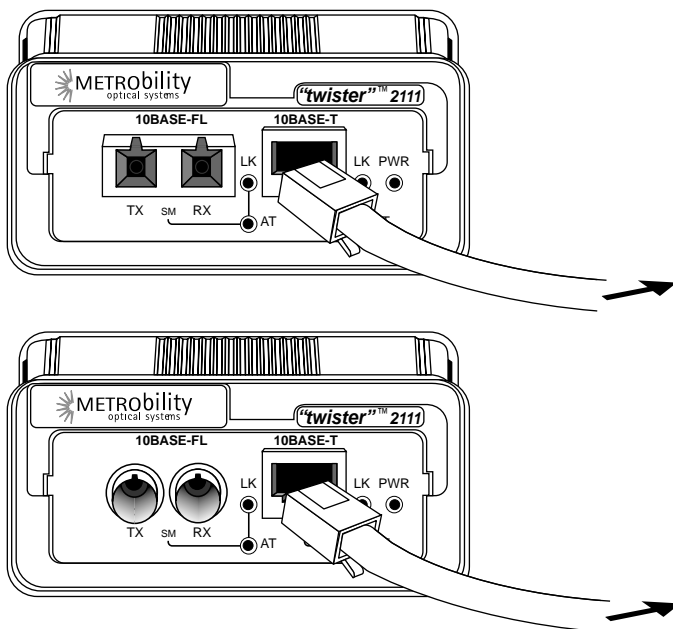

Fiber Optic Connections

These “twister” models support 10BASE-FL segments via ST, SMA or SC connectors.

- The 2111-13-01 provides one set of FL multimode SC connectors and supports a maximum segment length of up to 2km for remote links.
- The 2111-15-01 provides one set of FL multimode ST connectors and supports a maximum segment length of up to 2km for remote links.
- The 2111-16-01 provides one set of FL singlemode ST connectors and supports a maximum segment length of up to 14km for remote links.
- The 2111-18-01 provides one set of FL multimode SMA connectors and supports a maximum segment length of up to 2km for remote links.
- The 2111-1T-01 provides one set of FL multimode ST connectors and supports a maximum segment length of up to 5km for remote links.

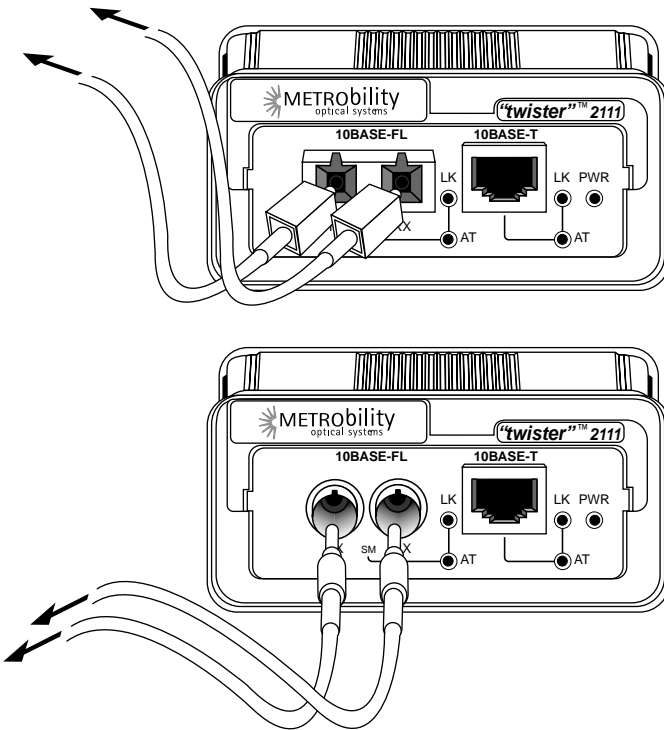

When making fiber optic connections, be sure that the transmit (TX) port of the “twister” connects to the receive (RX) port of the connected device; and be sure that the transmit (TX) port of the connected device connects to the receive (RX) port of the “twister” unit.

Once power is applied to the unit, correct connectivity can be verified via the LK (Link) LED.

BNC Connection (2111-12-01)

The “twister” 2111-12-01 attaches to thinnet coaxial cable via a standard BNC connector and supports a maximum segment length of 185 meters.

Termination ON

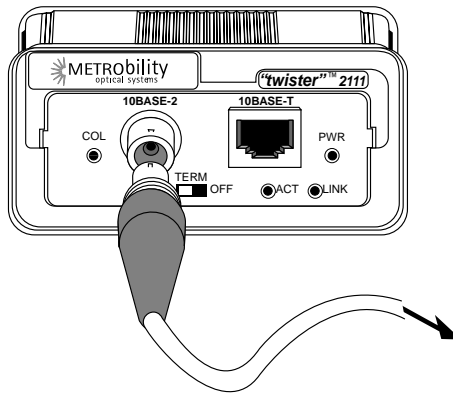

Termination OFF

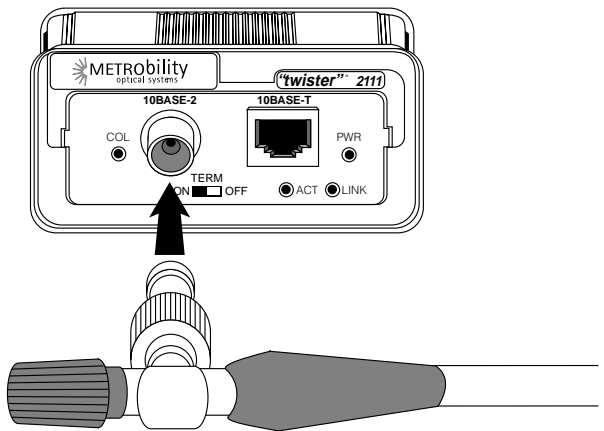

IMPORTANT: The coaxial cable of a LAN must be properly terminated at the end of each segment regardless of the device used at the end of each cable. One end of the two terminators on each segment must be grounded.

When the internal 50Ω termination switch is enabled (ON), the “twister” can be connected directly to a workstation or other device.

When the termination switch on the “twister” is disabled (OFF), you must attach a BNC terminator to the T-connector which connects to the unit.

The example below illustrates how to connect the “twister” 2111-12-01 when the termination switch is disabled and when it is enabled.

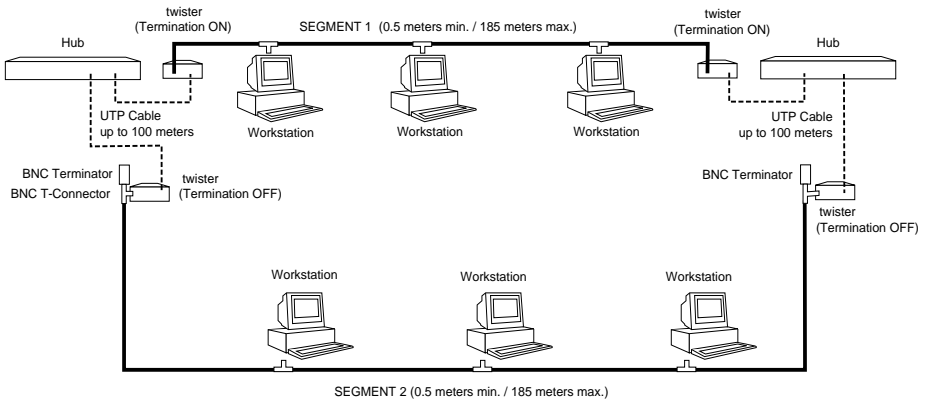

5 **Apply power.**

Power is provided to the “twister” unit from the 90-250V universal desktop power supply module. This power supply module is equipped with a S760 hollow-type plug for insertion into the DC jack located on the back of the “twister” unit and standard IEC 320-type AC power receptacle.

When making power connections, it is recommended that the DC power cord be connected to the DC input jack located on the back of the “twister” media converter *before* making the AC connection to the outlet. Be sure to seat the power cord into the strain relief clip to ensure against accidental disconnection.

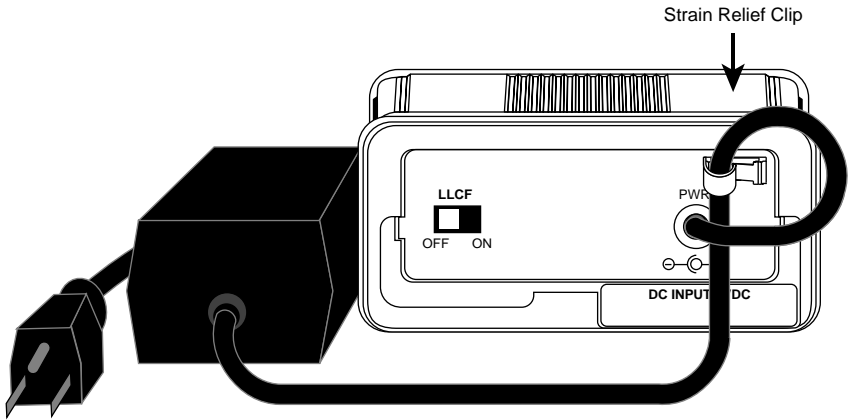

Upon receiving power, the “twister” media converter goes into normal operation mode and automatically provides the appropriate signal translation between the connected network segments.

Be sure to verify correct segment connectivity via the link (LK) LEDs on the front of the unit.

If an additional extension cord is used to connect the power module to the power source, the following guidelines must be followed.

While one end of the AC power cord can be fitted with whatever plug is standard for the country of operation, the end that connects to the “twister” power supply module must have a female plug that fits this type of AC receptacle.

- AC 115V (North American): use a UL-listed and CSA-certified cord set consisting of a minimum 18 AWG, type SVT or SJT three-conductor cord (15 feet maximum length) and a parallel blade grounding-type attachment plug rated 15A, 125V.
- AC 230V (USA): use a UL-listed cord set consisting of a minimum No. 18 AWG, type SVT three-conductor cord (15 feet maximum length) and a Tandem blade grounding-type attachment plug rated 15A, 250V.
- 240V (outside USA): use a cord set consisting of a minimum No. 18 AWG cord and grounding-type attachment plug rated 15A, 250V. The cord set should have the appropriate safety approvals for the country in which the “twister” 2111 is being installed and be marked HAR.

User Guide

This section contains more detailed user information regarding certain operating features for your “twister” media converter.

System LEDs

The Metrobility “twister” 2111 media converter provides LEDs for the visible verification of unit status and proper functionality as well as aiding in troubleshooting and overall network diagnosis and management.

LEDs indicate the following:

- PWR (power): the unit is ON and functioning in normal operation mode.
- LK: (link; twisted-pair and fiber optic ports): satisfactory link status on the respective port.
- AT (activity): the port is receiving data.
- COL* (collision): detection of a collision condition and subsequent JAM packets generated on both segments.

Once power is applied to the unit, verify correct connectivity via the LK LED.

* Applies to the “twister” 2111-12 only.

Link Loss Carry Forward (LLCF)*

The “twister” 2111 has been designed with a LLCF function for troubleshooting a remote connection. The unit is shipped with the LLCF disabled.

When LLCF is enabled, the fiber optic ports as well as the twisted-pair ports on the 2111 do not transmit a link signal until they receive a link signal from the opposite port. For example, if LLCF is enabled and two “twister” media converters are connected via a fiber cable with nothing else connected to them, the Link LED does *not* illuminate. When a valid link is established at the twisted-pair port, a complete connection is accomplished.

The diagram below shows a typical network configuration using “twister” media converters for remote connectivity:

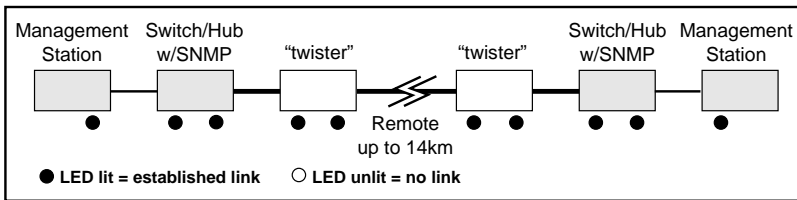

If the fiber connection breaks or the remote device fails, the “twister” media converter carries that link loss all the way to the switch/hub which generates a trap to the management station. The administrator can then look at the media converter to determine the source of the loss.

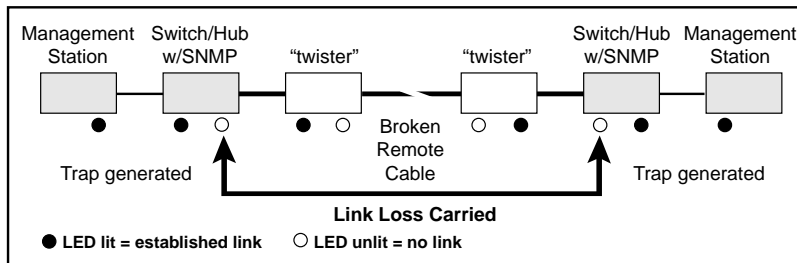

IMPORTANT: When connecting a “twister” media converter with LLCF enabled to an auto-negotiating device, force both sides of the configuration to 10Mbps full or half duplex. This allows the media converter to immediately see link pulses and start passing data.

* Does not apply to the “twister” 2111-12 (BNC).

Topology Solutions

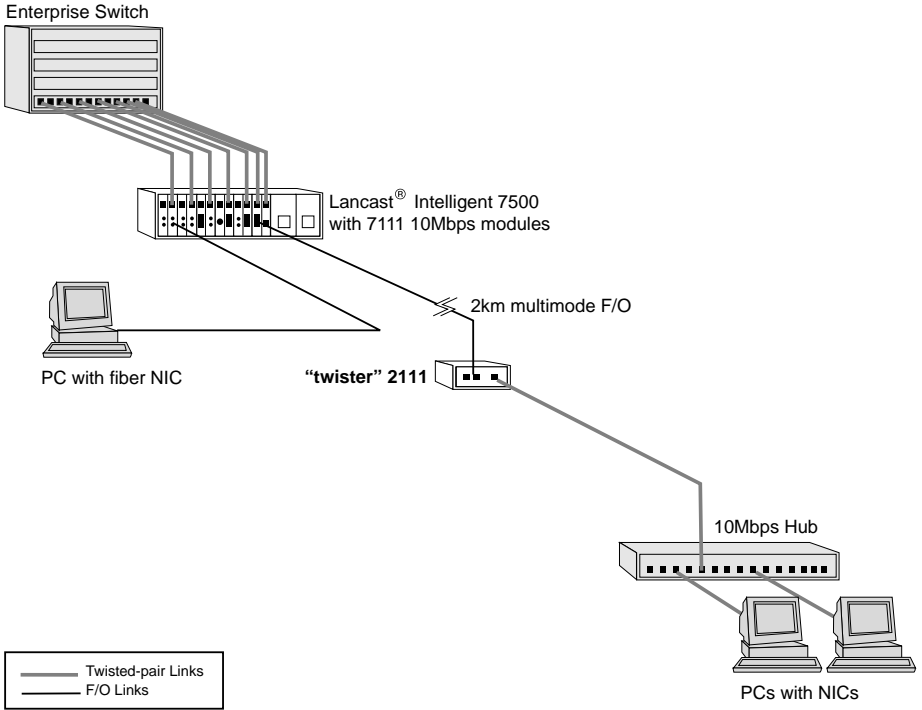

Technical Specifications

Data Rate

Data Rate _____ 10Mbps half duplex
_____ 20Mbps full duplex*
Bit Delay _____ < 5 bits

Network Connections

Twisted-Pair Interface

Connector _____ Shielded RJ-45, 8-pin jack
Impedance _____ 100 Ohms nominal
Signal Level Output (differential) _____ 2.0 to 2.8V
Signal Level Input _____ 350mV minimum
Supported Link Length _____ 100m
Cable Type _____ Category 3, 4, or 5 UTP
(EN55024:1998 compliance) _____ Category 5 STP

Multimode Fiber Optic Interface

(2111-13-01, 2111-15-01, 2111-18-01)

Connector _____ ST, SMA or SC
Wavelength _____ 850nm
RX Input Sensitivity _____ -32.5 dBm peak minimum
Output Power _____ -21.8 dBm to -16.8 dBm (50/125 μ m)
_____ -19 dBm to -14 dBm (62.5/125 μ m)
Supported Link Length _____ up to 2km full duplex
Cable Type _____ 50/125, 62.5/125, 100/140 μ m F/O

Multimode Fiber Optic Interface—Long Haul Distance Support

(2111-1T-01)

Connector _____ ST
Wavelength _____ 1300nm
Output Power _____ -23.5 dBm to -16 dBm (50/125 μ m)
_____ -20 dBm to -14 dBm (62.5/125 μ m)
Supported Link Length _____ up to 5km full duplex
Cable Type _____ 50/125, 62.5/125, 100/140 μ m F/O

Thinnet Coax Interface

(2111-12-01)

Connector _____ BNC receptacle
Internal Transceiver _____ IEEE 802.3
Supported Link Length _____ up to 185m
Cable Type _____ RG-58 coaxial cable

* Does not apply to the "twister" 2111-12 (BNC).

Singlemode Fiber Optic Interface

(2111-16-01)

Connector _____ ST
Wavelength _____ 1310nm
RX Input Sensitivity _____ -32.5 dBm peak minimum
Output Power _____ -23 dBm to -17 dBm (9/125 μm)
Supported Link Length _____ up to 14km full duplex
Cable Type _____ 8.3/125, 8.7/125, 9/125, 10/125 μm F/O

Power

Input _____ 90-250V AC 50/60 Hz
Output _____ +5VDC @ 1.2 A

Environmental

Operating Temperature _____ 0° to 55° C
Storage Temperature _____ -25° to 70° C
Relative Humidity _____ 5% to 95% non-condensing
Physical Case _____ Fully enclosed metal construction
Dimensions _____ 4.83" L x 3.26" W x 1.71" H
_____ 12.3 cm x 8.3 cm 4.3 cm
Weight (including power supply) _____ 3 lb, 1.36 kg

Product Safety, EMC and Compliance Statements

This equipment complies with the following requirements:

- UL
- CSA
- EN60950 (safety)
- FCC Part 15, Class A
- EN55022 Class A (emissions)
- EN55024: 1998 (immunity)
- IEEE 802.3
- IEC 825-1 Classification
- Class 1 Laser Product
- DOC Class A (emissions)

This product shall be handled, stored and disposed of in accordance with all governing and applicable safety and environmental regulatory agency requirements.

The following *FCC* and *Industry Canada* compliance information is applicable to North American customers only.

USA FCC Radio Frequency Interference Statement

This equipment has been tested and found to comply with the limits for a Class A digital device, pursuant to Part 15 of the FCC Rules. These limits are designed to provide reasonable protection against harmful interference when the equipment is operated in a commercial environment. This equipment generates, uses and can radiate radio frequency energy, and if not installed and used in accordance with the instruction manual, may cause harmful interference to radio communications. Operation of this equipment in a residential area is likely to cause harmful interference in which case the user will be required to correct the interference at his own expense.

***Caution:** Changes or modifications to this equipment not expressly approved by the party responsible for compliance could void the user's authority to operate the equipment.*

Canadian Radio Frequency Interference Statement

This Class A digital apparatus meets all requirements of the Canadian Interference-Causing Equipment Regulations.

Cet appareil numérique de la classe A respecte toutes les exigences du Règlement sur le matériel brouilleur du Canada.

Warranty and Servicing

Three-Year Warranty for Metrobility “twister” Media Converters

Metrobility Optical Systems, Inc. warrants that every “twister” media converter will be free from defects in material and workmanship for a period of THREE YEARS. This warranty covers the original user only and is not transferable. Should the unit fail at any time during this warranty period, Metrobility will, at its sole discretion, replace, repair, or refund the purchase price of the product. This warranty is limited to defects in workmanship and materials and does not cover damage from accident, acts of God, neglect, contamination, misuse or abnormal conditions of operation or handling, including overvoltage failures caused by use outside of the product’s specified rating, or normal wear and tear of mechanical components.

To establish original ownership and provide date of purchase, complete and return the registration card or register the product online at www.metrobility.com. If product was not purchased directly from Metrobility, please provide source, invoice number and date of purchase.

To return a defective product for warranty coverage, contact Metrobility Customer Service for a return materials authorization (RMA) number. Send the defective product postage and insurance prepaid to the address provided to you by the Metrobility Technical Support Representative. Failure to properly protect the product during shipping may void this warranty. The Metrobility RMA number must be clearly on the outside of the carton to ensure its acceptance.

Metrobility will pay return transportation for product repaired or replaced in-warranty. Before making any repair not covered by the warranty, Metrobility will estimate cost and obtain authorization, then invoice for repair and return transportation. Metrobility reserves the right to charge for all testing and shipping costs incurred, if test results determine that the unit is without defect.

This warranty constitutes the buyer’s sole remedy. No other warranties, such as fitness for a particular purpose, are expressed or implied. Under no circumstances will Metrobility be liable for any damages incurred by the use of this product including, but not limited to, lost profits, lost savings, and incidental or consequential damages arising from the use of, or inability to use, this product. Authorized resellers are not authorized to extend any other warranty on Metrobility’s behalf.

Product Manuals

The most recent version of this manual is available online at
<http://www.metrobility.com/support/manuals.htm>

To obtain additional copies of this manual, contact your reseller, or call
1.877.526.2278 or 1.603.880.1833

Product Registration

To register your product, go to
<http://www.metrobility.com/support/registration.cfm>

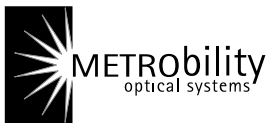

25 Manchester Street, Merrimack, NH 03054 USA
tel: 1.603.880.1833 • fax: 1.603.594.2887
www.metrobility.com